



SENSOR DEVELOPMENT, INC.

SANTA ANA, CALIF

(714) 836-7090

CS41 CONDUCTIVITY SENSORS

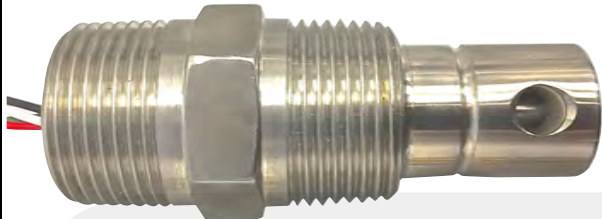

CS41 - 1.0 - 1" I.D.

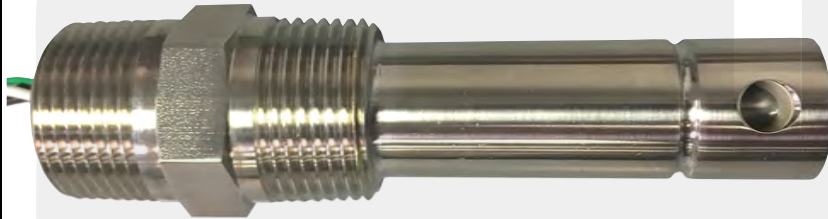

CS41 - 1.0 - 2" I.D.



CS41 - 0.1



CS41 - 1.0 - SANITARY



CS41 - 0.01

The CS41 line of conductivity sensors were designed for high pressure, high temperature measurements. Which makes it an ideal choice for boiler control applications. Including: blowdown control, condensate monitoring, leak detection on heat exchangers, and steam purity measurements. Those are a few of the many applications these rugged and reliable sensors can be used in. Wetted materials are 316L stainless steel electrodes, PEEK insulators, and EPR high-temp o-rings. FDA approved EPDM o-rings available upon request.

MAX. PRESSURE/TEMP. RATINGS:

- STANDARD SENSORS - 100psig @ 150°C
- HIGH TEMP SENSORS - 250psig @ 205°C
- EITHER SENSOR - 500psig @ 100°C
- SANITARY SENSOR - 150psig

WETTED MATERIALS:

- ELECTRODES - 316L STAINLESS STEEL
- INSULATORS - PEEK
- O-RINGS - HIGH TEMP EPR E0962-90, FDA APPROVED EPDM O-RINGS AVAILABLE

CELL CONSTANTS: 2.0 , 1.0 , 0.2 , 0.1 , 0.05 , 0.01 (2.0 , 0.2 , 0.05 NOT PICTURED ABOVE)

CONNECTION: PROCESS - 3/4" MNPT, SANITARY FLANGES AVAILABLE UPON REQUEST

TEMPERATURE COMPENSATION: Pt1000 STANDARD. OTHER OPTIONS: Pt100, 10KΩ, 3K BALCO, 8.55K NTC



SENSOR DEVELOPMENT, INC.

SANTA ANA, CALIF

(714) 836-7090

CS41 CONDUCTIVITY SENSORS

CS41 CONDUCTIVITY SENSORS PICTURED
WITH WEATHER PROOF, EXPLOSION PROOF
KILLARK GECEAT-2 JUNCTION BOX.

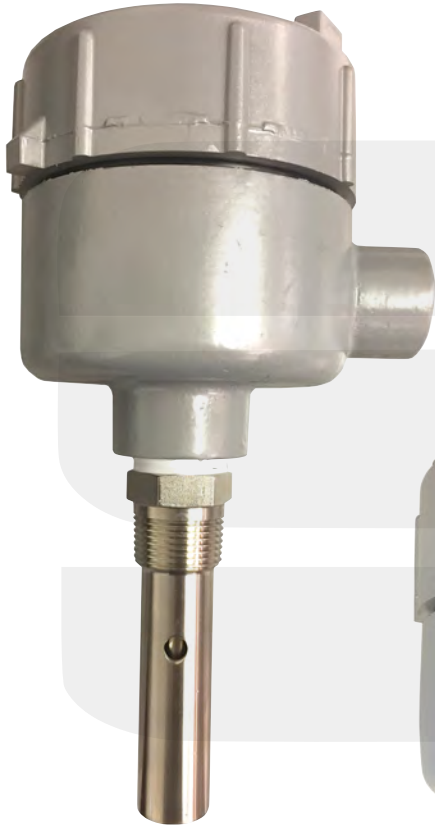

CS41 - 0.01



CS41 - 0.1



CS41 - 1.0 - 1"ID

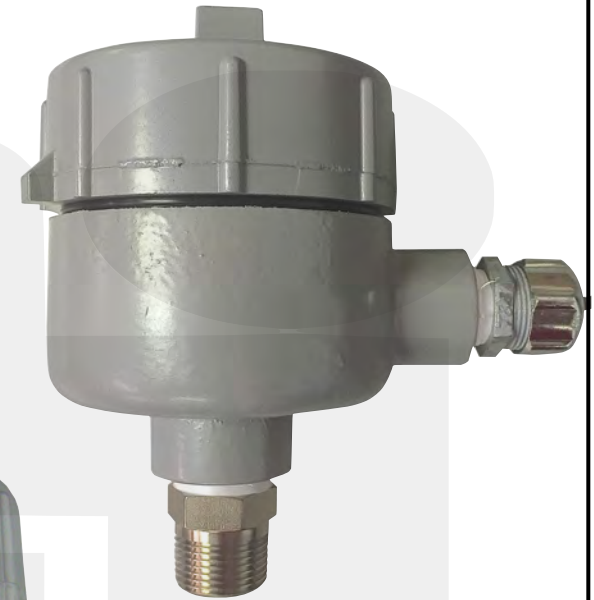

CS41 - 0.1



SENSOR DEVELOPMENT, INC.
SANTA ANA, CALIF (714) 836-7090

Model CS41 CONDUCTIVITY SENSOR

- **Measure conductivity directly in process temperatures up to 205°C**
- **O-ring seals used on all versions for high on-stream reliability**
- **Boiler condensate and blowdown control without coolers**

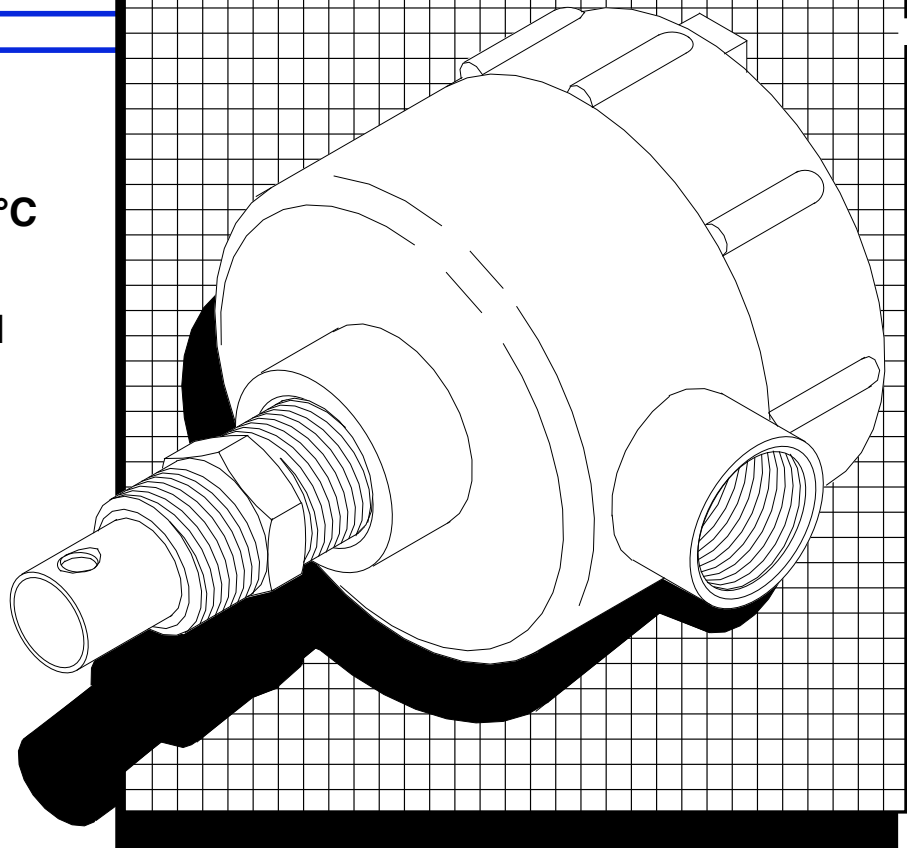

The Model CS41 sensor was designed for high pressure, high temperature conductivity measurements, and is an ideal choice for boiler control applications. Blowdown control, condensate monitoring, leak detection on heat exchangers, and steam purity measurements are just a few of the many applications in which this rugged and reliable sensor can be used.

Application Notes

Wetted materials of construction are 316 stainless steel, PEEK, and EPDM o-rings. All possible leak paths through the sensor are double sealed with o-rings for maximum on-stream reliability. Hot water is a severe environment for any elastomer, and the front seals bear the brunt of chemical attack, allowing the back seals to remain relatively unaffected. The result is that sensor life

is more than double what can be expected of single sealed, or epoxy sealed units.

Cell constant values from 2.0 to 0.05 are available, which will cover the ranges of interest in most boiler applications. Temperature compensation elements can be selected to interface with all major analyzer brands or on request to fit your system.

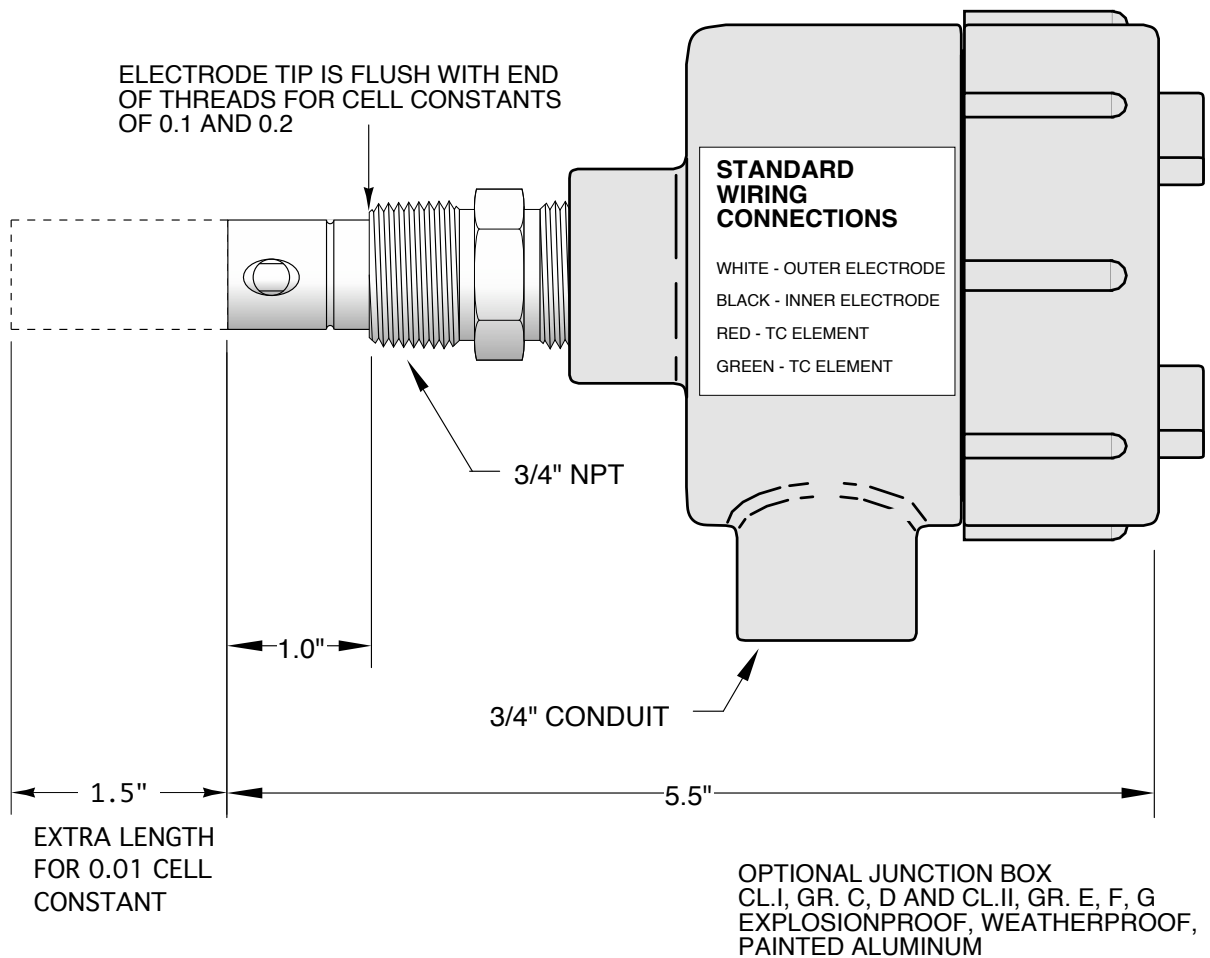

SPECIFICATIONS

MAX. PRESSURE/TEMP. RATINGS:

Standard Sensor - 100 PSIG at 150°C
Hi Temp. Sensor - 250 PSIG at 205°C
Either Sensor - 500 PSIG at 100°C

WETTED MATERIALS:

Electrodes - 316 Stainless Steel
Insulator - PEEK
O-Rings - Parker EPDM, Steam Service
 FDA APPROVED

CELL CONSTANT:

2.0, 1.0, 0.2, 0.1, 0.05, 0.01

CONNECTIONS:

Process - 3/4" MNPT

Electrical - 3/4" FNPT conduit hub; terminal strip to accept stripped leads, 14-24 ga.

TEMPERATURE COMPENSATION:

10KΩ@25°C/32.66KΩ@0°C NTC
 Available options include Pt1000, Pt100, 3K BALCO, 8.55K NTC, Ni100 and many others.
 Reference the make and model of instrument for assistance in selecting the right element.



SENSOR DEVELOPMENT, INC.
 SANTA ANA, CALIF (714) 836-7090